

## LOH 05501

**Compression pressure:** 0.2 to 2 bar  
**Volume flow:** 2.8 to 4.8 m<sup>3</sup>/h

### CONSTRUCTION

Sterling SIHI liquid ring compressors have a simple but robust construction with the following features and benefits:

- Capable of handling almost all gases and vapours
- Near isothermal compression
- Oil-free, with no internal lubrication
- Low maintenance and safe operation
- Low noise and almost vibration free
- Available in a wide range of materials
- Broad range of applications
- Rotating metallic parts are non contacting to minimise wear
- ATEX compliance

The LOH 05501 operates according to side channel principle and therefore the pump has the advantage, besides the above-mentioned features to handle large quantities of entrained liquid. Sterling SIHI liquid ring compressors of the range LOH 05501 are two-stage compressors. They can be used as vacuum pumps up to a suction pressure of 80 mbar without any modification. (See the Technical Catalogue – Liquid Ring Vacuum Pumps).



### APPLICATIONS

Pumping and compressing of dry gases and saturated vapours; the compressors can also handle liquids. The compressors are applied in all fields where a compression over pressure of up to 2 bar has to be created by robust compressors and only a small increase in temperature is admissible during compression.

Typical application areas include:

- the plastics industry, for recovery of process gases as vinyl chloride
- the petrochemical industry, for the compression of combustible gases as gasoline vapours or hydrogen
- transport of gases in general e.g. to a reactor

### NOTE

By continuously feeding the compressor with a small amount of service liquid (usually water), the heat due to gas/vapour compression is conducted away. This also replenishes the liquid ring and ensures that it does not become saturated with process media. Recharging the pump with service liquid at ambient temperature enables the unit to condense evacuated gases/vapours. It can therefore be used for solvent recovery. The condensed gas and liquid can be separated in a pressure liquid separator. More information is provided in the accessory catalogues.

The service liquid can simply be re-circulated.

The rotation of the pump is clockwise when viewed from the drive end.

### GENERAL TECHNICAL DATA

Pump Type	Units	LOH 05501	
Speed	rpm	1450	1700
Maximum overpressure on compression	bar	2	
Maximum permissible pressure difference	bar	3	
Hydraulic test pressure (overpressure)	bar	4	
Moment of inertia of rotating parts of pump and water content	kg · m <sup>2</sup>	0.0033	
Noise level at 80 mbar suction pressure	dB (A)	69	70
Minimum permissible pulley diameter for V belt drive	mm	100	112
Maximum gas temperature	dry °C	200	
	saturated °C	100	
Service liquid:			
Maximum permissible temperature	°C	80	
Maximum viscosity	mm <sup>2</sup> /s	90	
Maximum density	kg/m <sup>3</sup>	1200	
Liquid capacity up to middle of shaft	litre	1	
Maximum flow resistance of the heat exchanger	bar	0.2	

In selecting a pump, avoid choosing one which is likely to be operating at a combination of its maximum permissible limits e.g. maximum viscosity and maximum permissible pressure difference.

## Materials

Position Number	Component	Materials	
		01	32
0001, 0002	Casing	0.6025	2.1050.01
0010, 0011, 0012	Intermediate pieces		G Sn Bz 16
0030	Impeller	2.0550	2.1052.01
0200	Shaft	1.4021	1.4401
0400	Gland Packing	RAMIE	

## Cut-away diagram LOH 05501

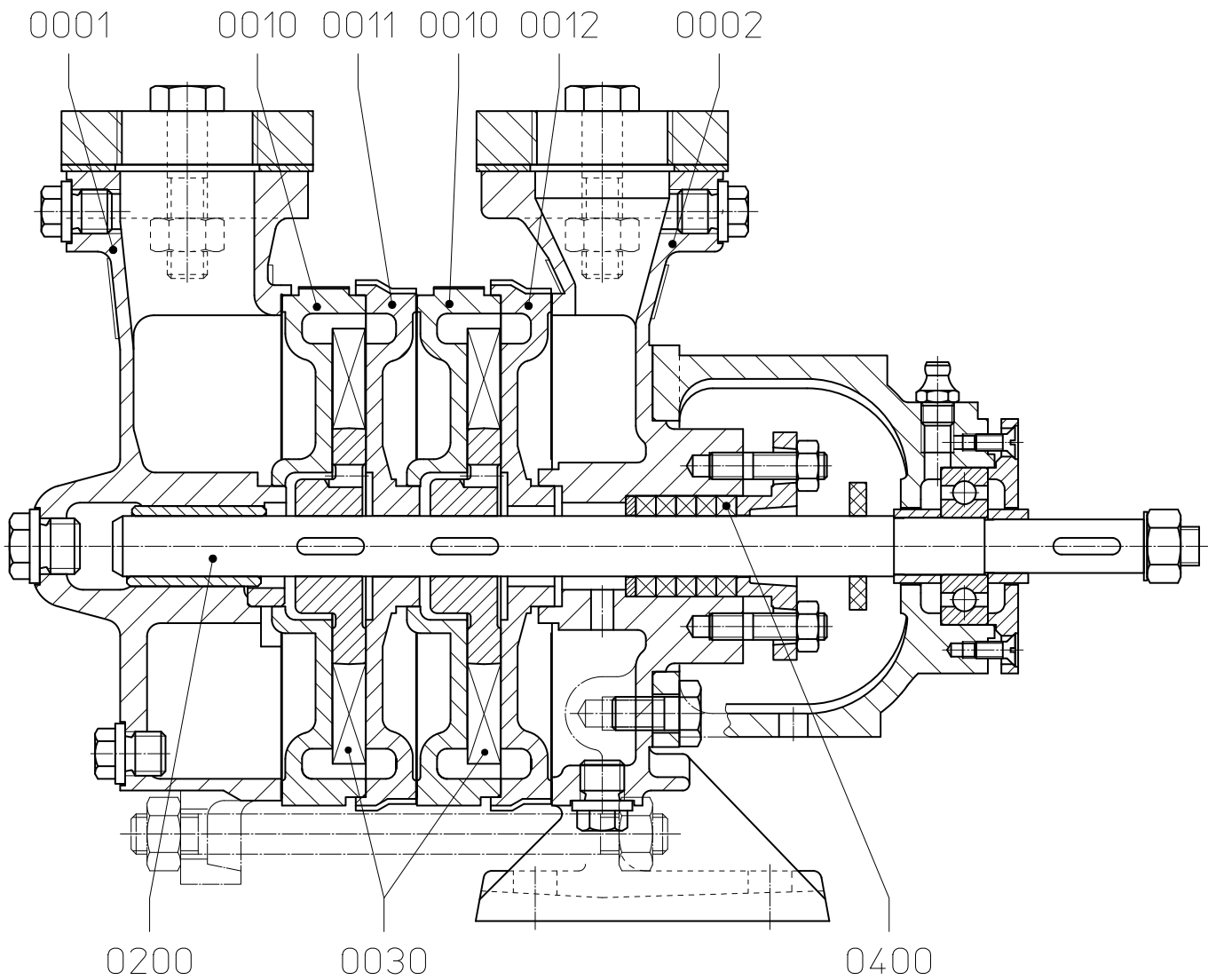

**Performance Characteristics LOH 05501**

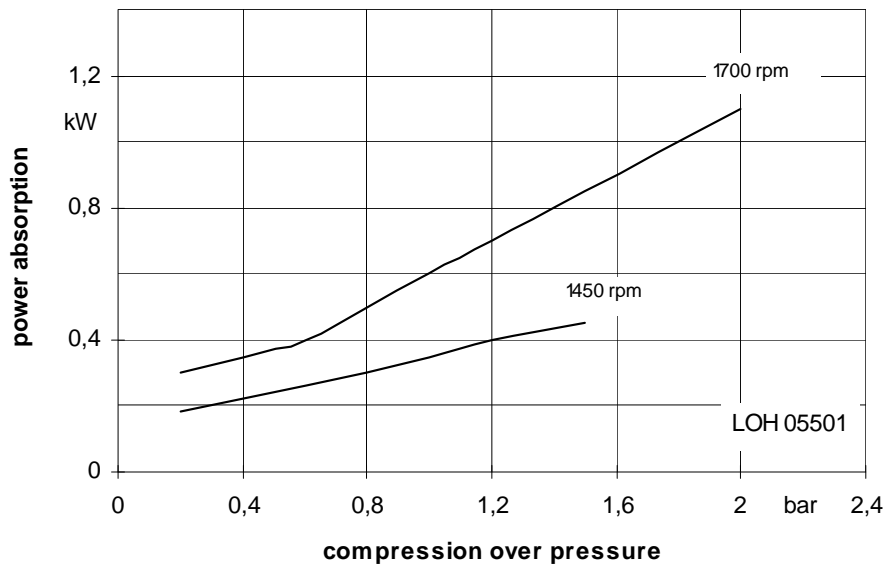
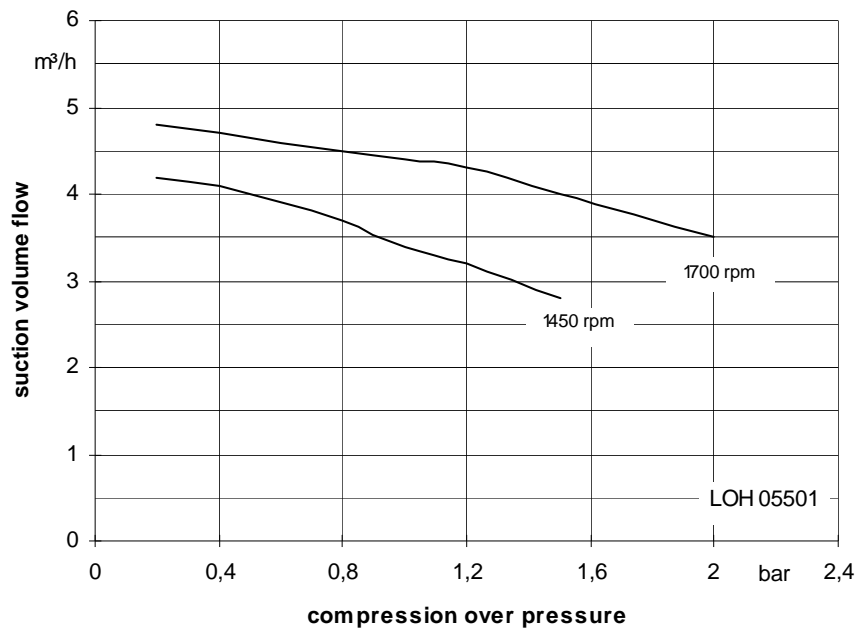

The values indicated for volume flow and power absorption are valid for compression of dry air at 20°C from atmospheric pressure (1013 mbar) to the respective compression pressure with water at 20°C as service liquid. Tolerance of the curve values is 10 %. The compression pressure in bar is indicated as pressure above the atmospheric pressure.

The data indicated change with deviating service conditions, such as deviating physical data of the gas to be handled or of the service liquid (vapour pressure, temperature, density, viscosity) when handling entrained liquid, at a suction pressure deviating from atmospheric pressure, when handling gas-vapours mixtures.

For determination of service data for deviating service conditions please see catalogue section TH.

## Dimensions LOH 05501

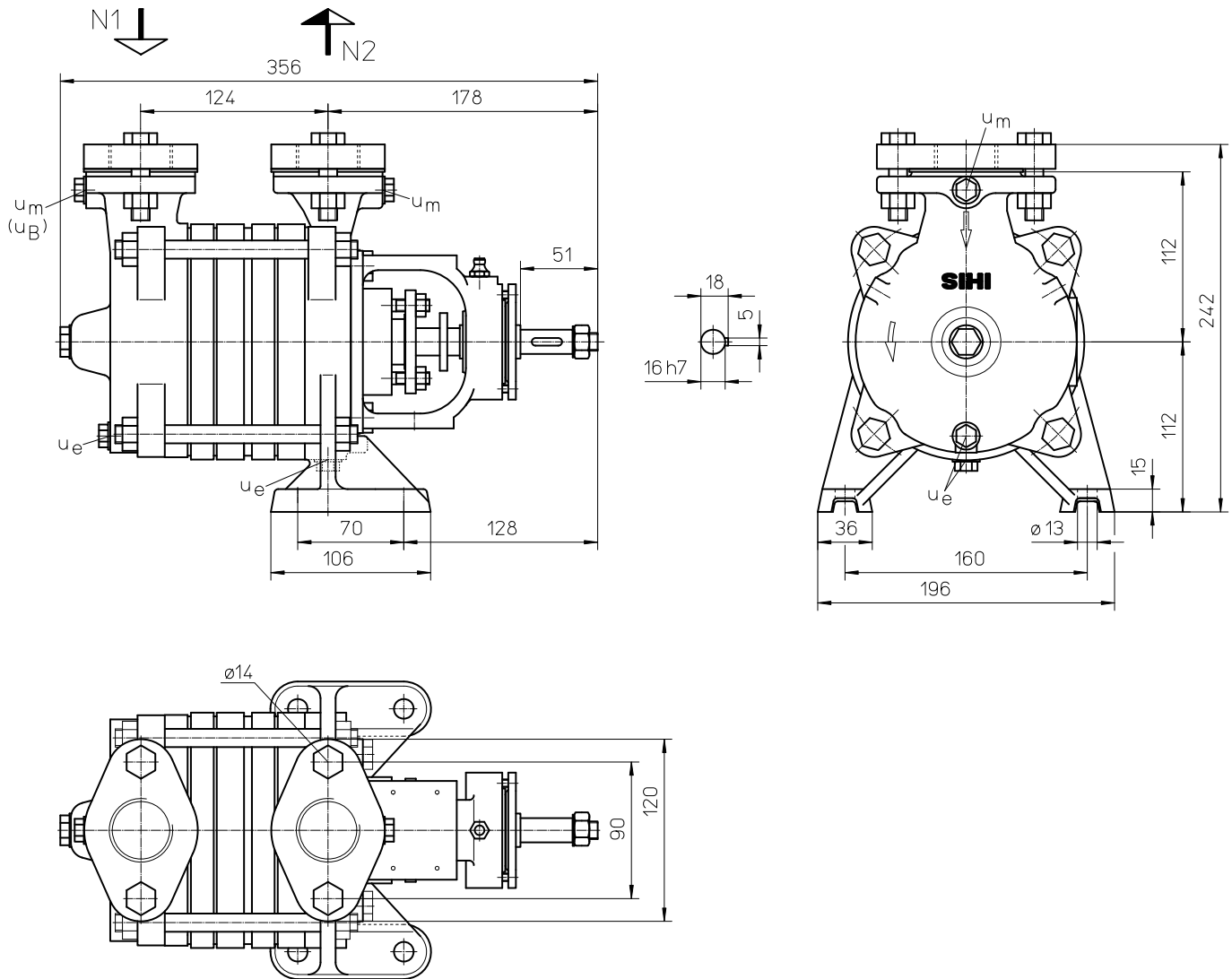

- N 1 = gas inlet      G 1 ¼
- N 2 = gas outlet    G 1 ¼
- U<sub>e</sub> = connection for drain G ¼
- U<sub>m</sub> = connection for pressure gauge G ¼

weight: 17 kg

The service liquid is fed into the suction line of the pump.

**Make-up liquid consumption** in [m<sup>3</sup>/h] dependent upon compression pressure, speed, drive type and temperature difference

Type	Speed [rpm]	Compression pressure in [bar]															
		1					FB	1.5				FB	2				FB
		KB				KB				KB							
		Temperature difference [°C]				Temperature difference [°C]				Temperature difference [°C]							
30	20	10	5	30	20	10	5	30	20	10	5						
LOH 05501	1450	0.01	0.01	0.03	0.05	0.2	0.01	0.02	0.03	0.06	0.2					0.2	
	1700	0.02	0.02	0.04	0.07		0.02	0.03	0.05	0.08		0.03	0.04	0.06	0.1		

FB = Total service liquid flow rate on once-through system

KB = Flow of make-up water when combined with partial recirculation liquid at a temperature of 30 °C, 20 °C, 10 °C, 5 °C warmer than make-up water.

**Product code - order details**

Range + Size	Bearings + Sense of rotation	Shaft Seal	Materials	Casing Sealing
	<ul style="list-style-type: none"> <li>A• One sleeve bearing, one greased roller bearing</li> <li>•N One shaft end, clockwise rotating</li> </ul>	001 Gland Packing, standard design	01 Main parts of cast iron 32 Main parts of bronze	0 Liquid seal
LOH 05501	AN	001	01, 32	0

**Motor Selection**

For our products we offer a lot of different motor types. To identify the right motor please specify frequency, voltage and protection class.

**Example of an Order:**

LOHE 05501 AN 001 01 0 with 0.55 kW AC motor, 50 Hz, 230V Δ, IP55

## Accessories

Recommended Accessory	Material Execution		LOH 05501
<b>Pressure liquid separator</b>		Type / Weight	XBd 413 / 28 kg
Pressure liquid separator	Steel, galvanised	SIHI-Part No.	on request
Bend	Steel	SIHI-Part No.	35 003 167
Service liquid pipework	Steel	SIHI-Part No.	35 003 084
<b>Liquid discharge trap</b>		Type / Weight	XUk 1602 / 11 kg
Liquid discharge trap	0.6020+1.4541	SIHI-Part No.	
Hanging gas line	Steel	SIHI-Part No.	
<b>Sterling SIHI – Non Return Ball valve</b>			
Intermediate flange execution XCK 32	0.6025 + Butadiene rubber 0.6025 + Teflon 1.4408 + Teflon	SIHI-Part No. Weight	20 072 744 / 1.2 kg 20 072 769 / 1.3 kg 20 029 488 / 3.0 kg
Flange execution with glass cylinder XCK 324	0.6025 + Butadiene rubber 0.6025 + Teflon 1.4408 + Teflon	SIHI-Part No. Weight	20 072 832 / 7.0 kg 20 072 833 / 7.0 kg 20 072 831 / 7.0 kg
<b>Motor</b>			
Motor Standard execution IP 55		Size Power Weight	80 0.55 kW 9 kg   80 0.75 kW 10 kg
Coupling for Motor IP 55 Pump side Motor side		Type / Weight SIHI-Part No. SIHI-Part No.	B 68 / 0.6 kg 43 040 236 43 021 404
Coupling guard	Steel	SIHI-Part No.	43 042 205
<b>Motor</b>			
Motor in EEx e II T3 execution		Size Power Weight	80 0.55 kW 9 kg   80 0.75 kW 11 kg
Coupling for Motor EEx e II T3 Pump side Motor side		Type / Weight SIHI-Part No. SIHI-Part No.	BDS 76 / 0.8 kg 43 040 236 43 025 690
Coupling guard	Brass	SIHI-Part No.	43 042 206
<b>Baseplate</b>	Steel	Type / Weight SIHI-Part No.	S 005 / 7 kg 43 040 645

Designs subject to change without prior notice.

### Sterling SIHI GmbH

Lindenstrasse 170, D- 25524 Itzehoe, Germany, Telephone +49 (0) 48 21 / 7 71 - 01, Fax + 49 (0) 48 21 / 7 71 - 274