

3-DELT KRYOGEN KUGLEVENTIL

TYPE DVC1380



armatec



GENERELT

DIMENSION/TRYK:	DN10 - DN50: PN130
MATERIALE:	SYREFAST RUSTFRIT STÅL
TILSLUTNING:	SVEJSENDER SCH. 40
INDBYGNINGSMÅL:	DIN3202 M3 S13
MONTAGEFLANGE:	ISO 5211
TEMPERATUR:	-196° C TIL +200° C
BETJENING:	HÅNDTAG

OPTION

DIMENSION:	DN8
TILSLUTNING:	FLANGER, INDSTIKSENDER (SVEJSE) GEVIND "BSP"
BETJENING:	PNEUMATISK AKTUATOR ELLER ELEKTRISK AKTUATOR

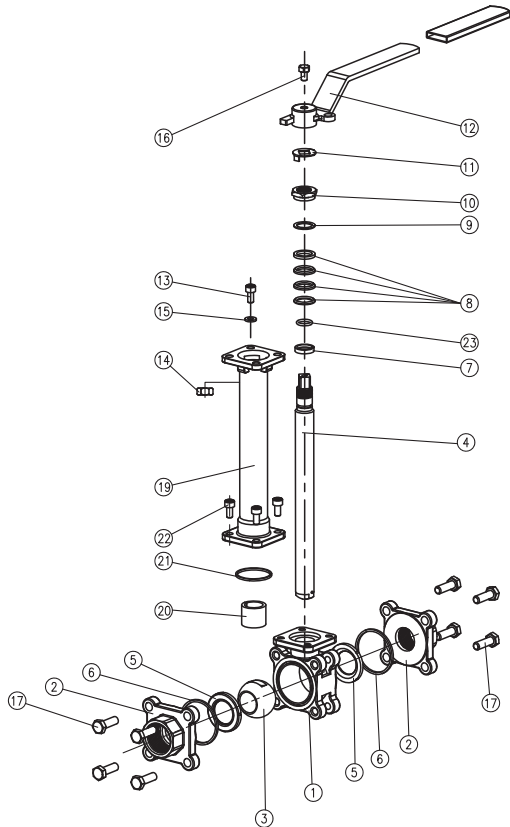

POS	BESKRIVELSE	MATERIALE
1	HUS	CF8M
2	TILSLUTNINGSENDE	CF3M / CF8M (GEVIND)
3	KUGLE	CF8M
4	SPINDEL	17- 4 PH SS
5	SÆDERING	PCTFE (KEL-F)
6	HUSPAKNING	GRAFOIL
7	TRYKSKIVE	PCTFE (KEL-F)
8	SPINDELPAKNING	PCTFE (KEL-F)
9	SPINDELPAKNING	PCTFE (KEL-F)
10	SPINDELMØTRIK	AISI 304
11	LÅSEBLIK	AISI 304
12	HÅNDTAG	AISI 304
13	STOPBOLT	AISI 304
14	STOPMØTRIK	AISI 304
15	STOPSKIVE	AISI 304
16	BOLT	AISI 304
17	HUSBOLT	AISI 304
18	GREB	VINYL
19	OVERDEL	CF8M
20	FORING	25% KULSTOF/75% PTFE
21	PAKNING	GRAFOIL
22	BOLT	AISI 304
23	O-RING	FPM

BESKRIVELSE

- **3-delt kryokugleventil med temperatur område fra -196°C til +200°C.** Velegnet til nitrogen, CO₂, oxygen osv. Alle ventiler er affedt for oxygen.
- **Lang hals** forhindrer tilfrysning af spindelpakdåsen, da denne sidder i toppen af spindelforlænger. Dette minimerer risikoen for lækage.
- **Alle kugler er aflastningsborede** for at forhindre termisk ekspansion.
- **Der foreligger materiale certifikat EN10204/3.1** på alle kugleventiler. Alle ventiler er affedt for oxygen.

VELEGNET TIL



INDUSTRI



MARINE



KØLEANLÆG

DIMENSIONER

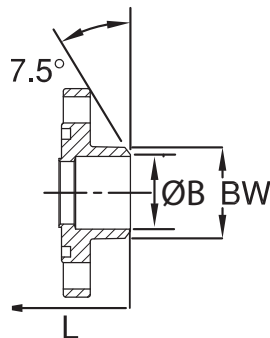
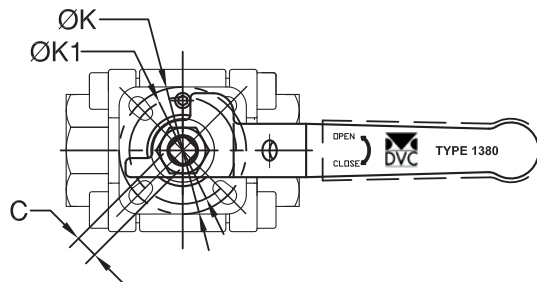
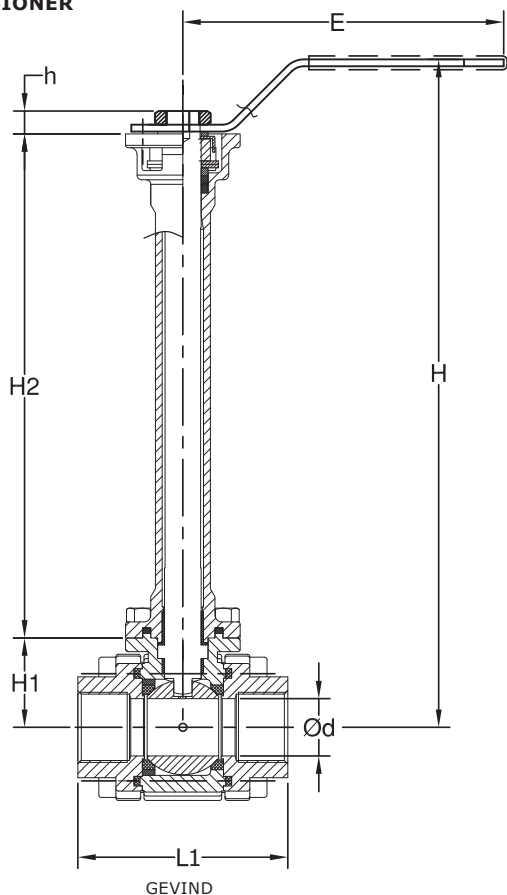

DIM	G ["]	øOD [MM]	L [MM]	L1 [MM]	E [MM]	H [MM]	H1 [MM]	H2 [MM]	h [MM]	C [MM]	ØK [MM]	ØK1 [MM]	ØB [MM]	BW [MM]	KV [NM ³ /H]	MOMENT [NM]		VÆGT [KG]	MAST* [KG]
																20°C	-196°C		
DN10	3/8	9,6	67	67	156	274	39,0	200	8	9	F05	F04	13,7	17,2	6,90	10,0	20,0	1,81	75
DN15	1/2	15,0	75	75	156	274	39,0	200	8	9	F05	F04	15,8	21,4	16,34	12,0	26,0	1,84	75
DN20	3/4	20,0	90	80	156	276	42,6	200	8	9	F05	F04	20,9	26,7	30,10	16,0	38,0	2,25	75
DN25	1	25,0	100	90	181	287	47,2	200	10	11	F07	F05	26,6	33,4	43,00	21,0	47,0	2,83	140
DN32	1 1/4	31,0	110	110	181	292	51,2	200	10	11	F07	F05	35,0	42,2	94,60	29,0	68,0	3,70	140
DN40	1 1/2	38,0	125	120	395	403	58,5	300	13	14	F10	F07	40,8	48,3	172,00	37,0	85,0	7,41	250
DN50	2	50,0	150	140	395	423	76,2	300	13	14	F10	F07	52,5	60,5	301,00	59,0	160,0	9,50	250

Momenter er inkl. 30% sikkerhedsfaktor

*) Max Allowed Stem Torque

TRYK/TEMPERATUR

