

**APPROVALS**



**ENGINEERING CODE**  
267FA42

**APPROVED REFRIGERANT**  
R-134a

**POWER SUPPLY**  
220-240 V 50 Hz

**STANDARD CONDITIONS**  
ASHRAE

**APPLICATION**  
LBP

**COOLING CAPACITY**  
186 W (LBP)

**EFFICIENCY**  
1.24 W/W (LBP)

**MOTOR TYPE**  
CSIR

**STARTING TORQUE**  
HST

**DATA**

**General Data**

Type	Hermetic reciprocating
Technology Type	On-Off
Displacement	7.37 cm <sup>3</sup>
Compressor Cooling	Static/NotControlled/220
Expansion Device	Capillary Tube or Expansion Valve
Horse Power	1/10 hp
Max Condensing Pressure Operating	13.92 bar
Max Condensing Pressure Peak	15.62 bar
Power Supply	220-240 V 50 Hz
Evaporating Temperature Range	-30 °C to -5 °C

**Electrical Data**

Motor type	CSIR
Starting Torque	HST

## Mechanical Data

Maximum Recommended Refrigerant Charge	350 g
Oil Charge	340 ml
Oil Type Configuration	ESTER
Oil Type Viscosity	ISO22
Pressurization	Dry air charge
Weight	10.4 Kg
Free Internal Volume	2.1 L

## Electrical Components

	Description
Motor Protection	T0827/G6
Start Capacitor	53-64 Uf / 330 V
Starting Device	Relay   MTRPH-0046-65*

## External Characteristics

Base Plate	European	
Tray Holder	No	
Height	188 mm	
Connector	Internal Diameter	Shape
Suction	6.1 mm	Slanted 42°/Copper
Discharge	4.94 mm	Straight/Copper
Process	6.1 mm	Slanted 42°/Copper

## PERFORMANCE

## Rated Points

Condensing Temperature	Evaporating Temperature	Cooling Capacity	Power Consumption	Gas Flow Rate	Efficiency
54.40°C	-23.30°C	186 W	150 W	3.61 kg/h	1.24 W/W

Test Condition: ASHRAELBP32, Static/NotControlled/220, Return Gas 32.2°C, Evaporation -23.30°C, Condensing 54.40°C, Ambient 32.2°C, Liquid 32.2°C, Subcooling 22.2K. Data are an indication of performance based simulation.

## Performance Curve Data

### Condensing Temperature 35°C

Evaporating Temperature °C	Cooling Capacity W	Power W	Gas Flow Rate kg/h	Efficiency W/W
-30	146	118	2.83	1.24
-25	201	135	3.90	1.49
-20	266	154	5.17	1.73
-15	340	173	6.63	1.96
-10	423	194	8.28	2.18
-5	516	217	10.13	2.38

Test Condition: ASHRAELBP32, Static/NotControlled/220, Return Gas 32.2°C, Ambient 32.2°C, Liquid 32.2°C. Data are an indication of performance based simulation.

### Condensing Temperature 45°C

Evaporating Temperature °C	Cooling Capacity W	Power W	Gas Flow Rate kg/h	Efficiency W/W
-30	130	119	2.51	1.09
-25	184	139	3.57	1.33
-20	248	161	4.82	1.55
-15	322	184	6.28	1.75
-10	406	210	7.94	1.93
-5	499	238	9.79	2.09

Test Condition: ASHRAELBP32, Static/NotControlled/220, Return Gas 32.2°C, Ambient 32.2°C, Liquid 32.2°C. Data are an indication of performance based simulation.

### Condensing Temperature 55°C

Evaporating Temperature °C	Cooling Capacity W	Power W	Gas Flow Rate kg/h	Efficiency W/W
-25	165	141	3.20	1.17
-20	229	166	4.44	1.38
-15	302	193	5.89	1.56
-10	385	223	7.54	1.73
-5	479	256	9.40	1.87

Test Condition: ASHRAELBP32, Static/NotControlled/220, Return Gas 32.2°C, Ambient 32.2°C, Liquid 32.2°C. Data are an indication of performance based simulation.

## Operating Envelope

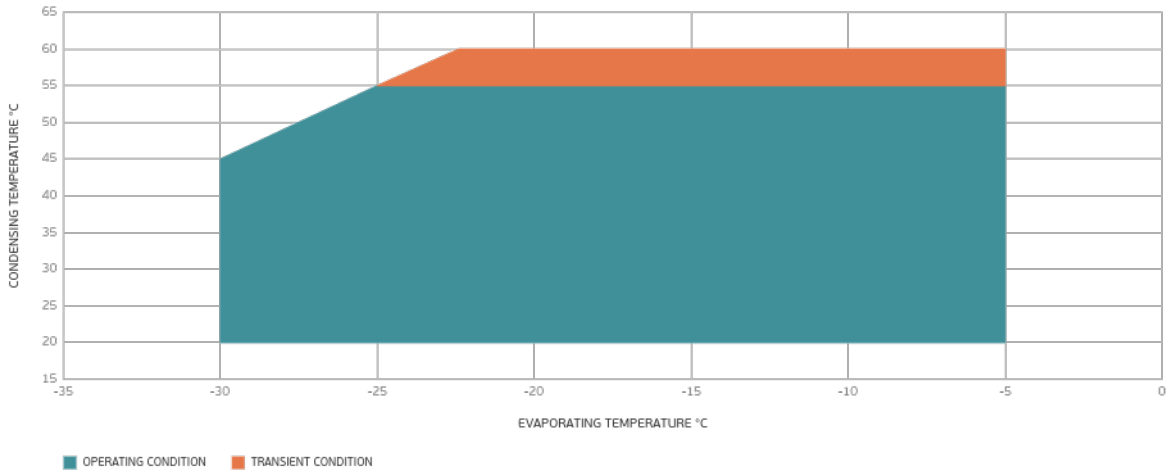

## External Dimensions

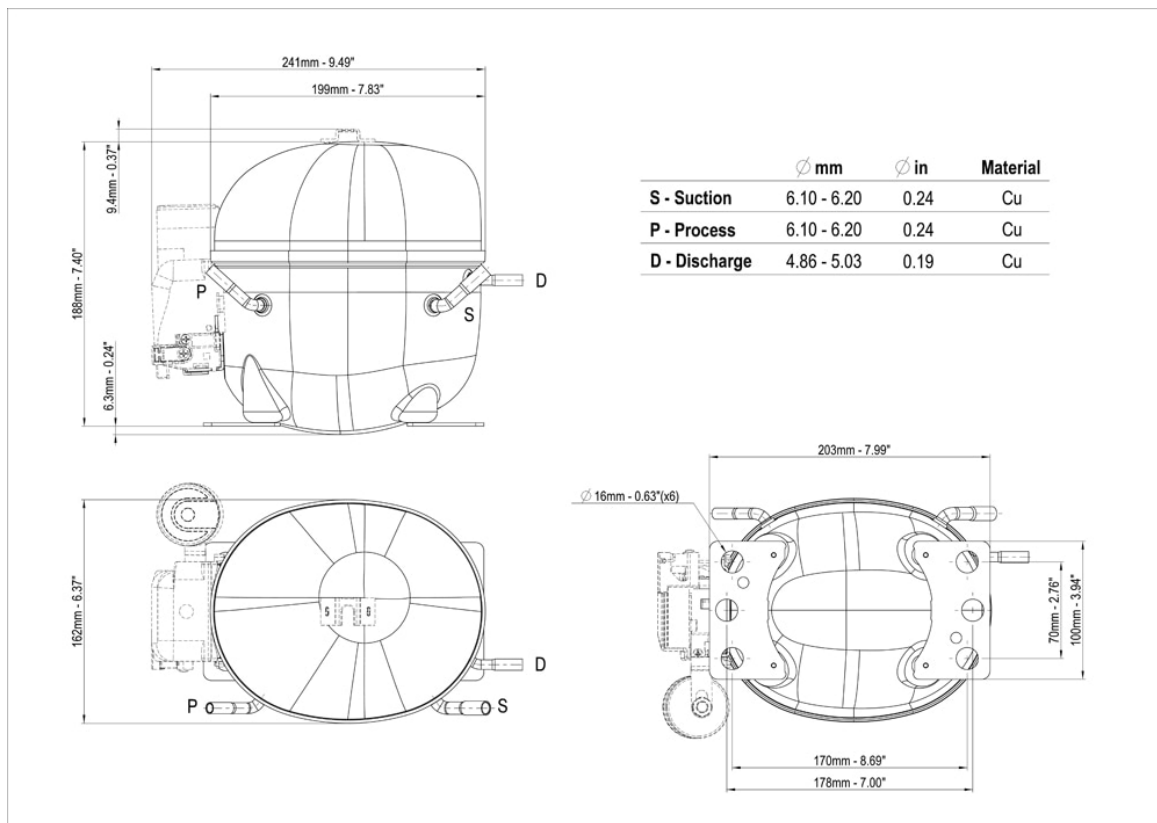

## Wiring Diagram

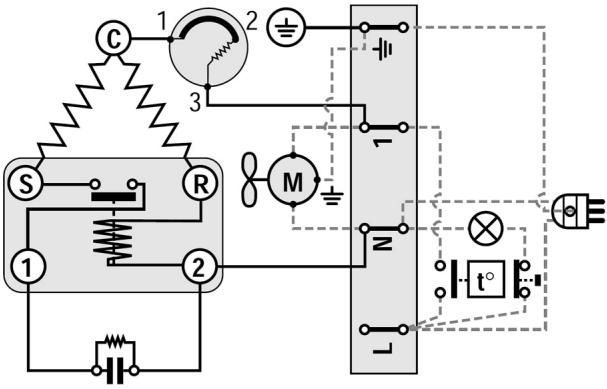

## Assembly Instructions

