

**resideo**

Product information

Protection module type AB with air gap for liquid category 5 according to SS-EN 1717. Design with integrated container and centrifugal pump.

Dimension range (litres)	13
PN	6
Temperature (°C)	5 - 35
Main material	Plastic

Area of use

To protect the internal and external drinking water systems against backflow and overpressure, a protective cover for liquid up to category 5 is required. The backflow prevention is of type AB with an air gap in accordance with SS-EN 1717.

It meets the requirements for connecting drinking water to:

Flushing at sewage treatment plants, agriculture, flushing and cleaning of sanitary equipment in hospitals or other applications where air gaps are required.

This backflow prevention is an excellent choice for professional users who demand the highest quality and performance.

Tender text

PSG.261 Backflow preventers with air gap

Backflow prevention device AT 1162C, protection module type AB with air gap for protection covering of liquid category 5 according to SS-EN 1717. Made with a polyethylene tank, volume of 100 litres. Centrifugal pump with flow up to a maximum of 4.0 m³/h and maximum pump head of 43 meters, see pump curve.

Quality assurance

Fluid category 5, SS-EN 1717

Fluid category 5, SS-EN 1717

Product marking: Information about the year of manufacture, manufacturing number, model, electrical data, IP rating, as well as pressure/flow, are specified on the unit's nameplate. CE marked.

Energy and environment declaration

Reach date: 6/14/2023 12:00:00 AM

Pos	Component	Material
-----	-----------	----------

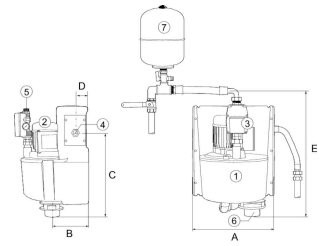

Measurements and weight

Dimension range (litres): 13

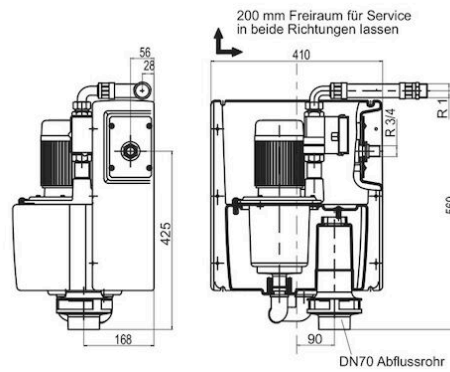

DN	A	B	C	D	E	Net weight (kg)
25	410	168	425	56	569	25

Function and design

Backflow prevention device type AB covers the risks up to liquid category 5 when connecting tap water. That is, "Liquid that poses a health risk due to the presence of microorganisms or viruses". The air gap in the module meets the requirements of the standard.

The protective module consists of a pump with a regulator and an integrated buffer tank. The unit is equipped with an overflow that is connected to a drainage pipe and led to a floor drain. The included pressure equalization vessel provides smooth operation and reduces the number of pump starts.

The module's design allows for easy installation, and its convenient size allows it to be mounted in tight spaces. The unit is designed for permanent installation on a wall with included wall brackets.

A pressure sensor continuously detects changes in the system, such as draining, and starts the pump when the pressure drops below 2.5 bar. When draining stops, the pump automatically stops after 10 seconds. The regulator automatically refills the buffer tank using an integrated level switch.

Technical data

Main material: Plastic

Included materials: Brass, Steel, Plastic

Temperature (°C): 5 - 35

PN: 6

ETIM classification: EC004501 - Backflow preventer

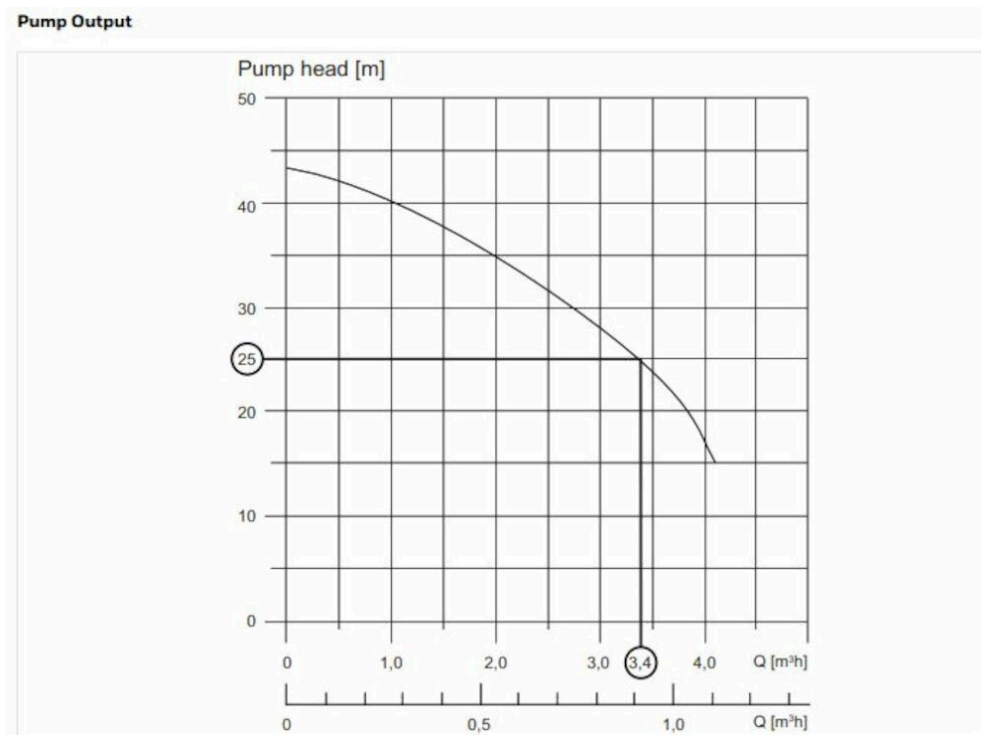

Installation and maintenance

Flowdirection: Uni-directional

Possible mounting position: Vertical

During installation, the incoming water pressure must not exceed 4.0 bar. If necessary, install a pressure reducing valve AT 4169-XX. The unit must be maintained according to the manufacturer's instructions. For more information, refer to the user manual.

Please feel free to contact us

We answer your questions by e-mail and telephone. No question is too small, no challenge is too big. You are always welcome at Armatec.

info@armatec.se | +46 31 89 01 00 | www.armatec.se

THE COMPANY'S MANAGEMENT SYSTEM
IS CERTIFIED BY DNV
ISO 9001 • ISO 14001