



V231 can be used in a wide range of applications, such as heating, district heating and air handling systems.

If the valve is used for media at temperatures below 0 °C (32 °F), it should be equipped with a stem heater in order to prevent ice formation on the valve stem.

The valve can handle the following types of media:

- Hot and chilled water.
- Water containing phosphate or hydrazine additives.
- Water with antifreeze additives such as glycol.

TECHNICAL SPECIFICATION

Design two-way plug valve
 Pressure class PN 25 (362 psi)
 Flow characteristic EQM
 Stroke 20 mm (0.79 in.)
 Rangeability $K_v/K_{v_{min}}$ see table
 Leakage up to 0,02% of K_v/C_v
 ΔP_m max. 800 kPa (116 psi), water
 Max. temperature of medium: 150 °C (302 °F)
 Min. temperature of medium: -20 °C (-4 °F)

Flanges drilling according to SS 335 and ISO 2084

Materials:

- Body nodular iron SS 0727 (GGG40.3)
- Plug and seat stainless steel SS 2346
- Stem stainless steel SS 2346

Standard packing box Venta

Conn. DN	in.	Kvs m ³ /h	Cvs	Item number excl. connection	Rangeability
15	½"	0.25	0.29	721-3106-000	> 50
15	½"	0.40	0.47	721-3110-000	> 50
15	½"	0.63	0.74	721-3114-000	> 50
15	½"	1.0	1.2	721-3118-000	> 50
15	½"	1.6	1.9	721-3122-000	> 50
15	½"	2.5	2.9	721-3126-000	> 50
15	½"	4.0	4.7	721-3130-000	> 50
20	¾"	6.3	7.4	721-3134-000	> 200
25	1"	10	11.7	721-3138-000	> 200
32	1¼"	16	18.7	721-3142-000	> 200
40	1½"	25	29.3	721-3146-000	> 200
50	2"	38	44.5	721-3150-000	> 200

Key:

- The rangability is the ratio of K_v and $K_{v_{min}}$ (C_v and $C_{v_{min}}$).
- K_v (C_v) is the flow through the valve in m³/h at the specified valve lift and at a pressure drop of 100 kPa across the valve.
- $K_{v_{min}}$ ($C_{v_{min}}$) is the minimum controllable flow (m³/h) at a pressure drop of 100 kPa within the range in which the valve characteristics conform to the slope requirements of IEC 534-1.
- ΔP_m is the maximum pressure drop across the fully open valve.

DESIGN AND CHARACTERISTICS

The design of the V231 gives good resistance against solid particles in the fluid.

The plug is guided throughout the lift, which reduces the risk for vibrations. The valve closes with the stem up.

The flow characteristics of the V231 is equal percentage modified. This characteristic makes it possible to control low flow rates down to almost closed position. This is particularly important for achieving good control performance in systems with wide load variations.

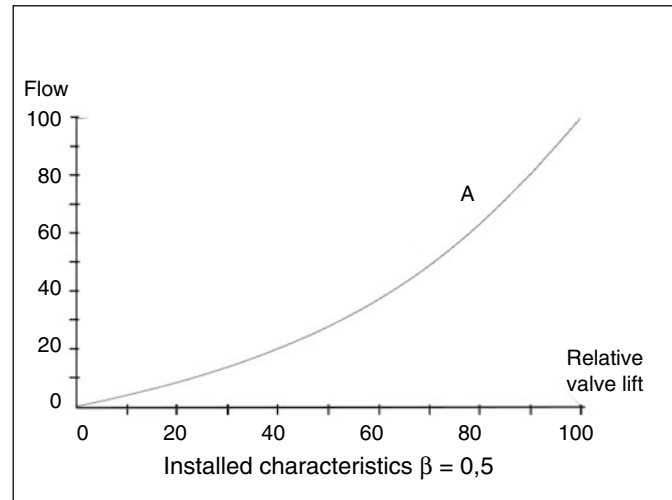
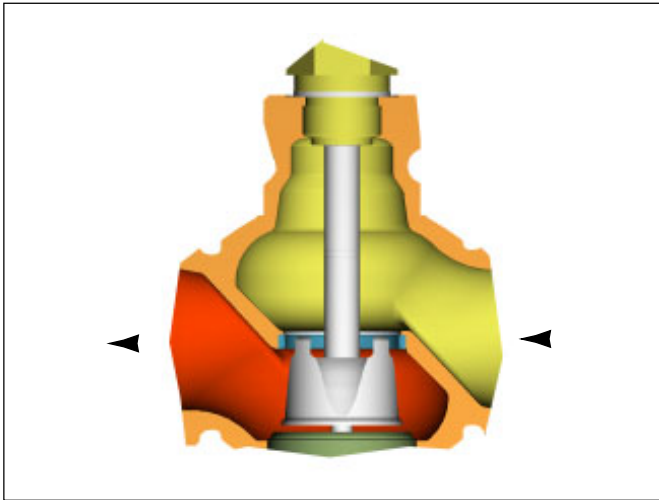

CAVITATION

Cavitation takes place in a valve when the velocity of the flow between the plug and seat increases to the extent that gas bubbles are created in the water.

When, after the plug and seat, the velocity decreases, the gas bubbles collapse (implode), generating considerable noise and causing considerable wear on the valve.

By means of the cavitation diagram shown in the figure it can be checked if risk of cavitation exists with the working conditions in the pertinent installation. Proceed as follows:

Using the static pressure before the valve (e.g. 1000 kPa), plot a horizontal line to the line for the temperature of the liquid (e.g. 120 °C).

From the intersection point, plot a vertical line downwards and read off the max. permissible pressure drop across the valve.

If the computed pressure drop exceeds the value read from the diagram there is risk of cavitation.

Pressure drop chart at the beginning of cavitation

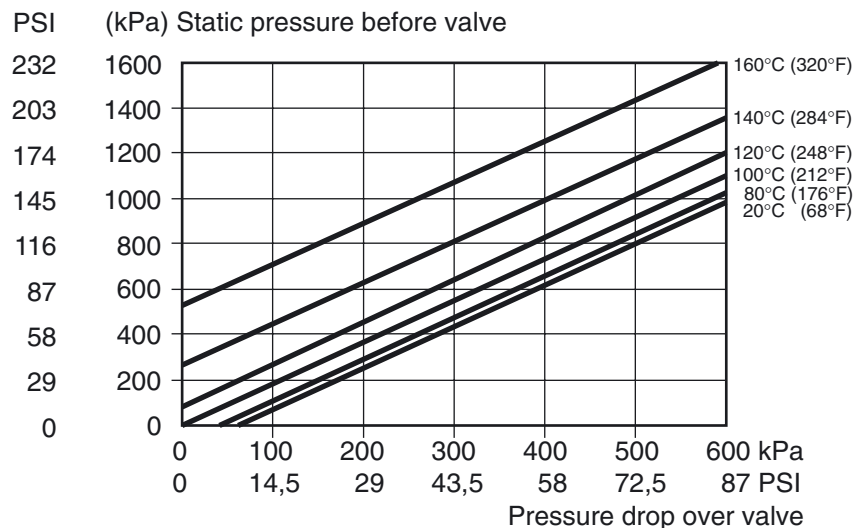

SPECIFICATION OF ACTUATOR

Use the diagram below to select actuator motor for the V231 to close required ΔP_c . A suitable actuator is selected, using the data sheet F-10-6.

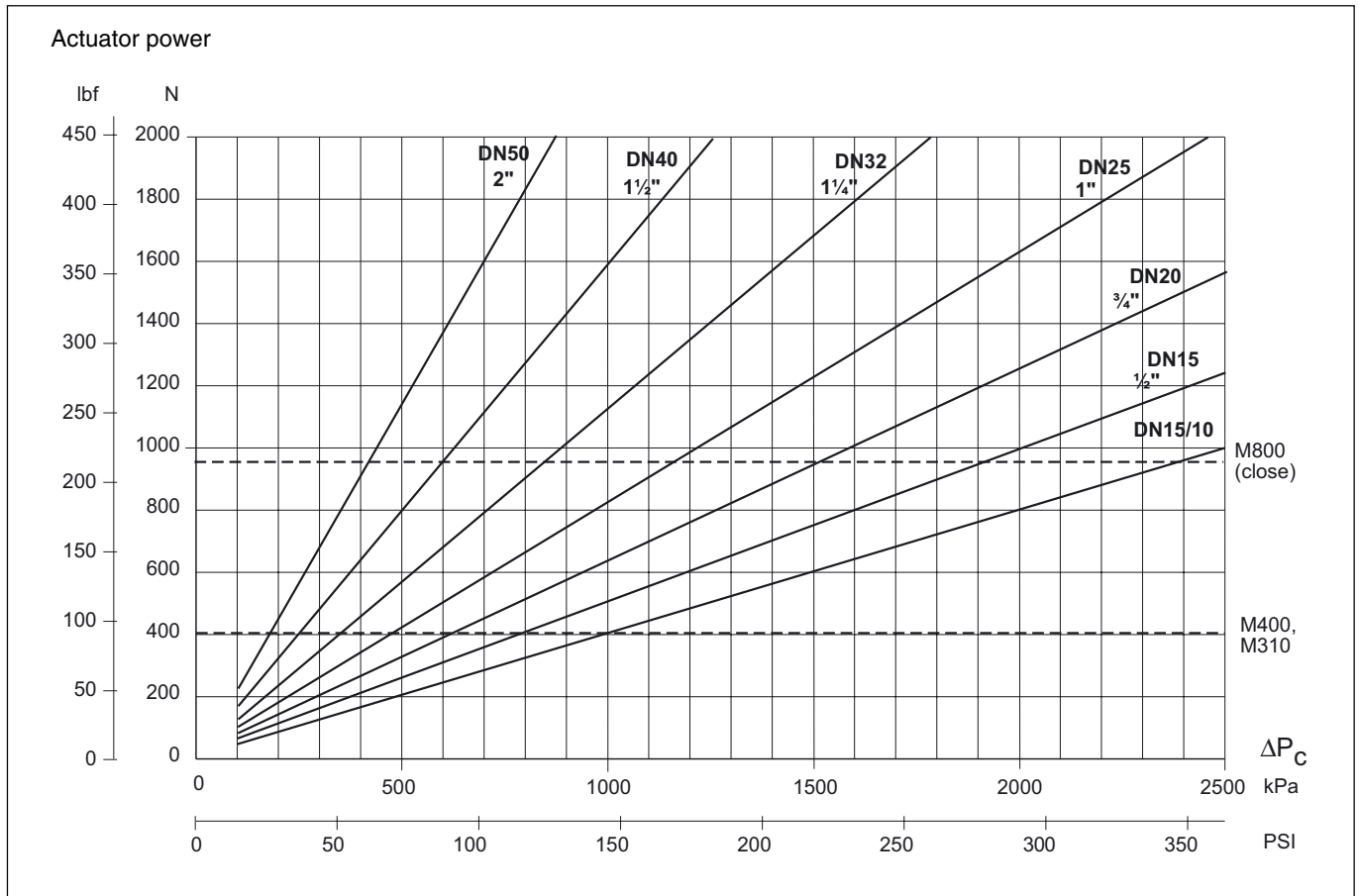

INSTALLATION

The valve should be mounted with flow direction in accordance with the valve marking.

It is recommended to install the valve in the return pipe, in order to avoid exposing the actuator to high temperatures.

The valve must not be installed with the actuator mounted below the valve.

To ensure that suspended solids will not become jammed between the valve plug and seat, a filter should be installed upstream of the valve, and the pipe system should be flushed before the valve is installed.

A Typical installation without local circulating pump.

To provide a good function, the pressure drop across the valve should be no less than half of the available pressure (ΔP). This corresponds to a valve authority of 50%.

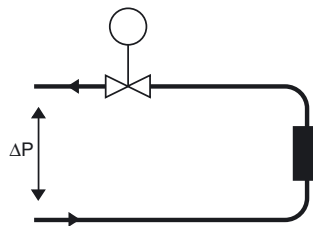

B Typical installation with local circulating pump.

The K_v (C_v) value of the valve to be selected so that the entire available pressure drop (ΔP) falls across the control valve.

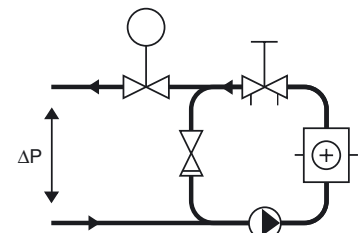

PRESSURE DROP CHART

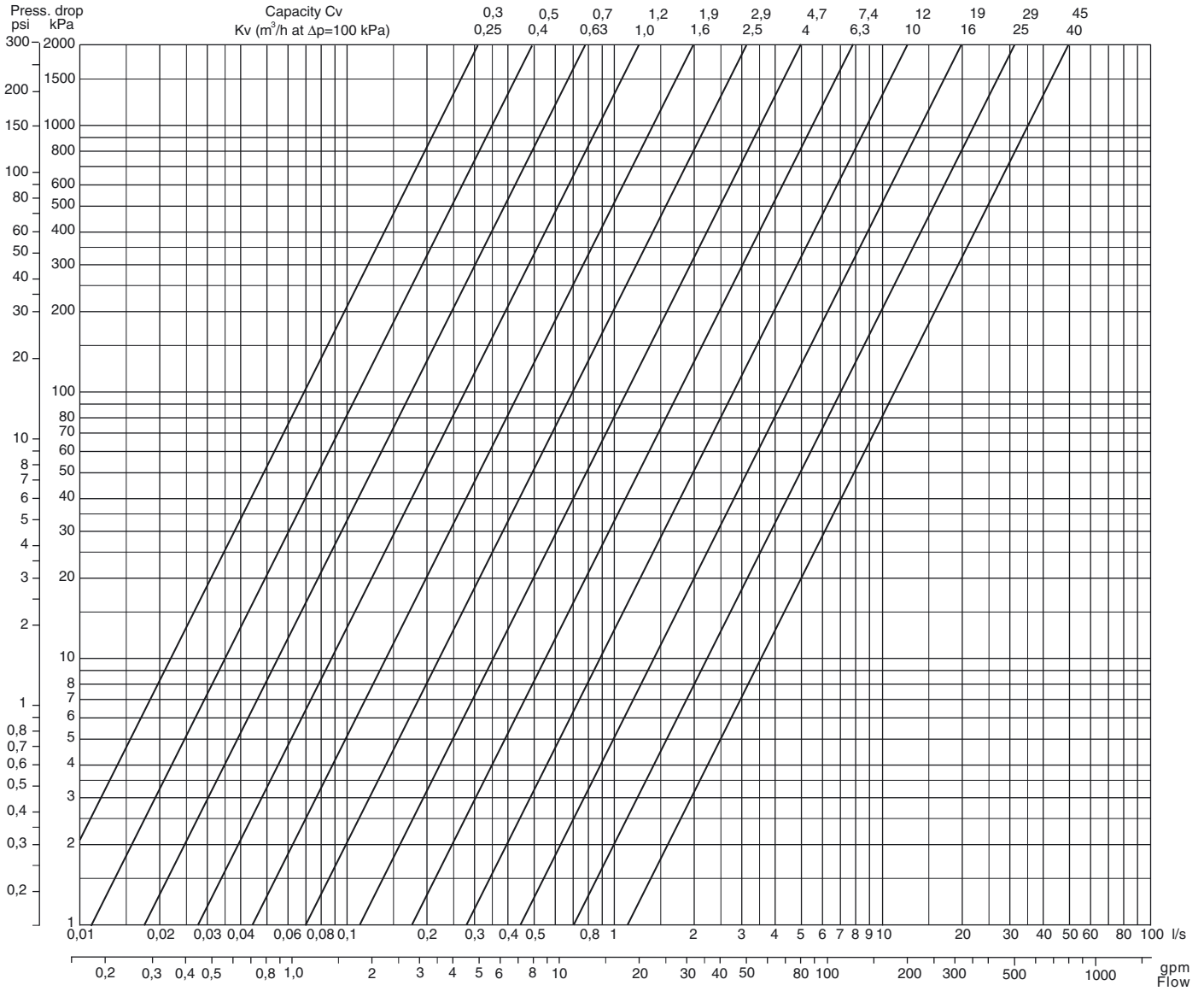

DIMENSIONS AND WEIGHTS

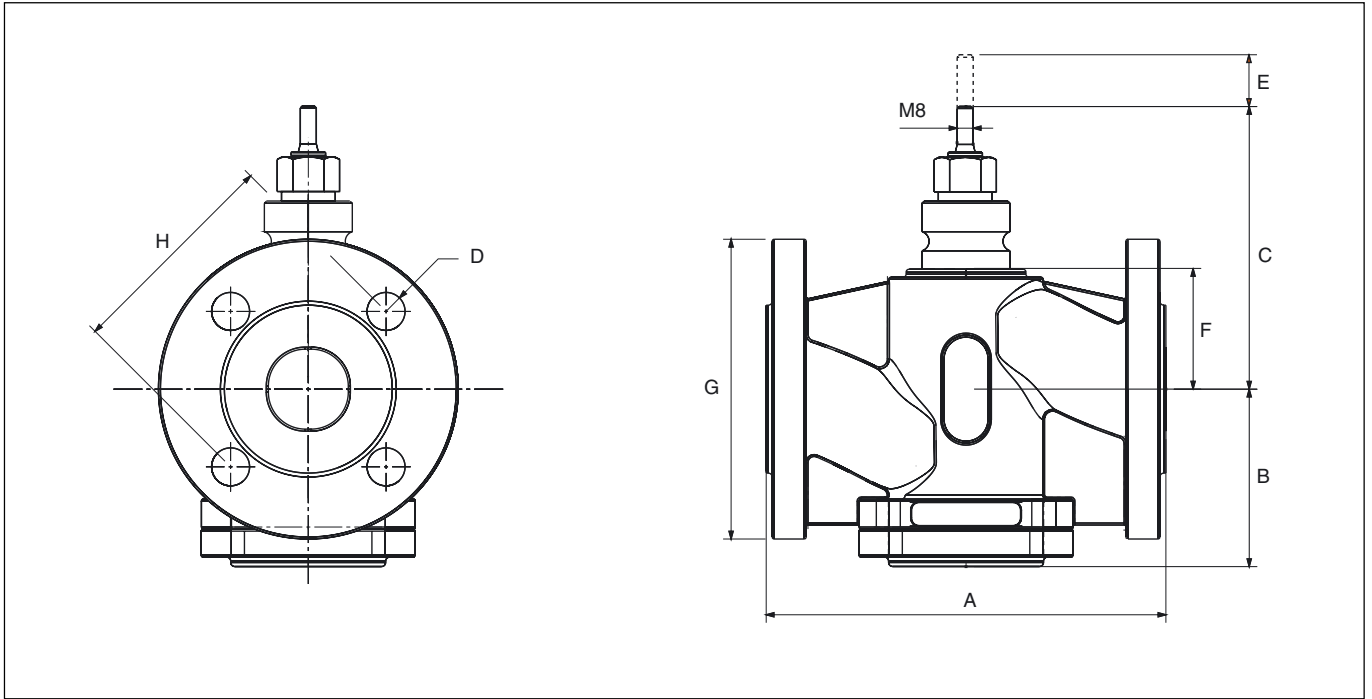

Part no.	Conn. DN	in.	Dimensions										Weight							
			A		B		C		D		E		F		G		H		kg	lb.
721-			mm	in.	mm	in.	mm	in.	mm	in.	mm	in.	mm	in.	mm	in.	mm	in.		
3106	15	½"	130	5.12	81	3.19	121.5	4.78	4x14	4x0.55	20	0.79	37	1.46	95	3.74	65	2.56	3.6	8
3110	15	½"	130	5.12	81	3.19	121.5	4.78	4x14	4x0.55	20	0.79	37	1.46	95	3.74	65	2.56	3.6	8
3114	15	½"	130	5.12	81	3.19	121.5	4.78	4x14	4x0.55	20	0.79	37	1.46	95	3.74	65	2.56	3.6	8
3118	15	½"	130	5.12	81	3.19	121.5	4.78	4x14	4x0.55	20	0.79	37	1.46	95	3.74	65	2.56	3.6	8
3122	15	½"	130	5.12	81	3.19	121.5	4.78	4x14	4x0.55	20	0.79	37	1.46	95	3.74	65	2.56	3.6	8
3126	15	½"	130	5.12	81	3.19	121.5	4.78	4x14	4x0.55	20	0.79	37	1.46	95	3.74	65	2.56	3.6	8
3130	15	½"	130	5.12	81	3.19	121.5	4.78	4x14	4x0.55	20	0.79	37	1.46	95	3.74	65	2.56	3.6	8
3134	20	¾"	150	5.91	92	3.62	124.5	4.90	4x14	4x0.55	20	0.79	40	1.57	105	4.13	75	2.95	4.4	10
3138	25	1"	160	6.30	96	3.78	129.5	5.10	4x14	4x0.55	20	0.79	45	1.77	115	4.53	85	3.35	5.6	12
3142	32	1¼"	180	7.09	100.5	3.96	143	5.63	4x19	4x0.75	20	0.79	58.5	2.30	140	5.51	100	3.94	7.7	17
3146	40	1½"	200	7.87	99	3.90	144.5	5.69	4x19	4x0.75	20	0.79	60	2.36	150	5.91	110	4.33	8.8	19
3150	50	2"	230	9.06	111	4.37	159.5	6.26	4x19	4x0.75	20	0.79	75	2.95	165	6.50	125	4.92	12.6	28

SPARE PARTS

Stuffing box

Standard type S . max 150 °C (302°F)

Item number 1-001-0800-0

(Blank page.)