

**DN8**

Item	Qty	Part Number	Description	Material	Treatment
1	1	24399	PIPE-DN8 TWIST-ACB	TUBE TWIST ACB-8.4x12.8-GREY-5x0.30 PET	-
2	1	24445	SLEEVE-DN8	Stainless Steel AISI 304	-
3	1	24446	SLEEVE-DN8-BLANK	Stainless Steel AISI 304	-
4	1	24464	NIPPLE-G1/2" Mltr.L13 DN8-DZR	Brass CW626N	-
5	1	24465.3	LISO-12 Mltr.L13 DN8-DZR	Brass CW626N	Nickel-plated
6	1	23432.3	NUT-G1/2"-H11-SW22.3	Brass CW617N	Light blasting + Nickel-Plated
7	1	11823	JGP-10.5X18X2-1/2	EPDM	-
8	1	22012	NEUTRAL LABEL	Polypropylene (>PP<)	-

Part Number	Description	Hose length	ARMATEC Reference	ARMATEC Description
212149	TWIST-ACB-HL-1212-300-ARMATEC	305 +/-5	5745AKF830012120	Slang AKF DN8 300 inv 1/2" x slät 12
212150	TWIST-ACB-HL-1212-400-ARMATEC	405 +/-5	5745AKF840012120	Slang AKF DN8 400 inv 1/2" x slät 12

**General Notes:**

- All dimensions are in mm.
- Product marking according to Tucai Engineering Standard ET-050.
- Pressing parameters according to Tucai Engineering Standard ET-035.
- Width across flat surfaces according to DIN 475-1.
- General and geometrical tolerances according to ISO 2768-mK.
- Surface texture according to ISO 1302.
- Hose length not to scale.
- Packaging specific for client - No mention of Tucai in packaging.
- Working Parameters:
  - Minimum operating temperature: -20°C
  - Maximum operating temperature: 90°C
  - Maximum operating pressure: 10 bar

ANGULAR TOLERANCE FOR LENGTH RANGE (SHORTER SIDE OF ANGLE)	up to 10	over 10 up to 50	over 50 up to 120	over 120 up to 400
	± 1'	± 0° 30'	± 0° 20'	± 0° 10'
NO SHARP EDGES PERMITTED	UNSPECIFIED RADIUS 0.5mm			
	Width across flat surfaces according to DIN 475-1			
MACHINING TOLERANCE (ISO-2768-m) LINEAR DIMENSIONS	0.5 up to 5 mm	over 5 up to 30	over 30 up to 120	over 120 up to 400
	± 0.1	± 0.2	± 0.3	± 0.5
BRASS MATERIAL SHALL BE STRESS RELIEVED	C			
	INSPECTION DIMENSION			

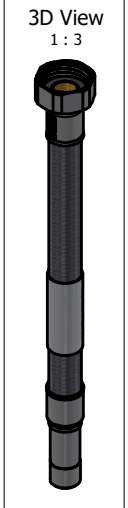
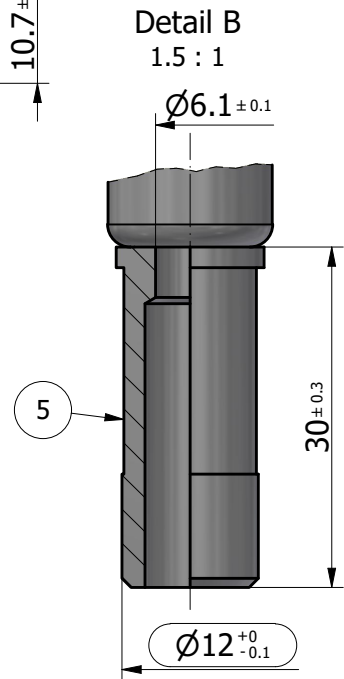
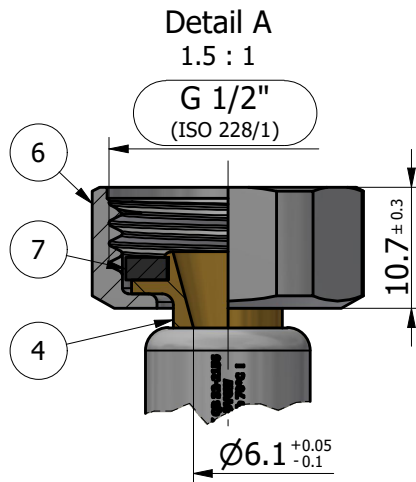
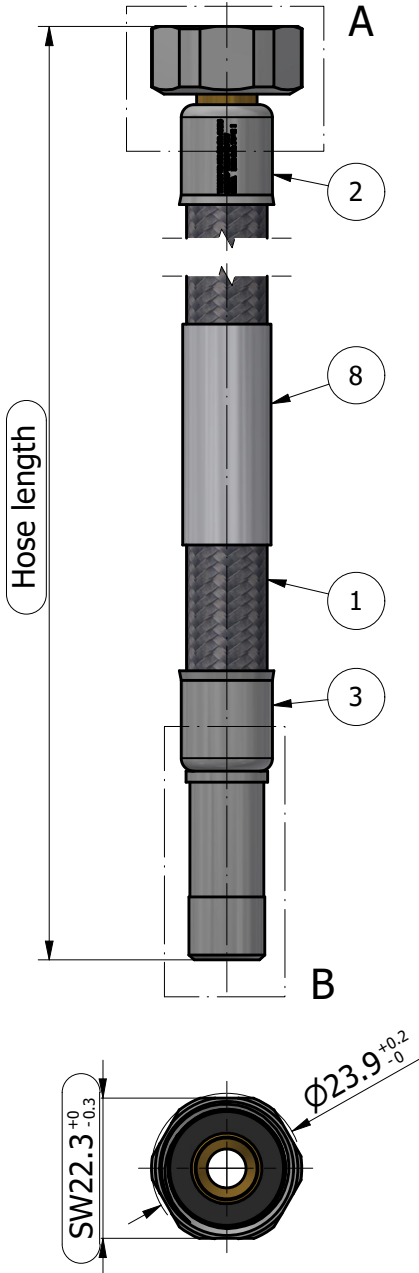

a	25/11/2024	Initial release.	9775	GRG	DDO
REV	DATE	DESCRIPTION	PET	DESIGNER	CHECKED BY

DESIGNER	GRG	25/11/2024
APPROVED BY	DDO	25/11/2024

# HOSE ASSEMBLY



TWIST-ACB-HL-1212-ARMATEC

Code  
**212149-T**

Code Prot.: -