

Item	Qty	Part Number	Description	Material	Treatment
1	1	24168	PIPE DN19 TWIST-ACB	Corrugated PE-RT Braiding PET	-
2	2	23467	SLEEVE-DN19	Stainless Steel AISI 304	-
3	2	24048	NIPPLE-DN19-G3/4	Brass CW626N	-
4	2	11451.9	NUT-G-3/4" H14	Brass CW617N	Blasting
5	2	12962	JFP G3/4"	FIBER	-
6	1	13436	Label	Polypropylene (PP)	-

Part Number	Description	Hose Length	ARMATEC Reference.	ARMATEC Description
212173	EXTRA-TWIST-ACB-DN19-HG-3434-200-ARMATEC	205 ± 5	5745AKF192003434	Slang AKF DN19 200 inv 3/4" x inv 3/4"
212174	EXTRA-TWIST-ACB-DN19-HG-3434-400-ARMATEC	405 ± 5	5745AKF194003434	Slang AKF DN19 400 inv 3/4" x inv 3/4"
212175	EXTRA-TWIST-ACB-DN19-HG-3434-600-ARMATEC	610 ± 10	5745AKF196003434	Slang AKF DN19 600 inv 3/4" x inv 3/4"
212176	EXTRA-TWIST-ACB-DN19-HG-3434-800-ARMATEC	810 ± 10	5745AKF198003434	Slang AKF DN19 800 inv 3/4" x inv 3/4"
212177	EXTRA-TWIST-ACB-DN19-HG-3434-1000-ARMATEC	1010 ± 10	5745AKF1910003434	Slang AKF DN19 1000 inv 3/4" x inv 3/4"
212178	EXTRA-TWIST-ACB-DN19-HG-3434-1200-ARMATEC	1215 ± 15	5745AKF1912003434	Slang AKF DN19 1200 inv 3/4" x inv 3/4"
212179	EXTRA-TWIST-ACB-DN19-HG-3434-1500-ARMATEC	1515 ± 15	5745AKF1915003434	Slang AKF DN19 1500 inv 3/4" x inv 3/4"
212180	EXTRA-TWIST-ACB-DN19-HG-3434-2000-ARMATEC	2015 ± 15	5745AKF1920003434	Slang AKF DN19 2000 inv 3/4" x inv 3/4"

- General Notes:
- All dimensions are in mm.
  - Product marking according to Tucai Engineering Standard ET-050.
  - Width across flat surfaces according to DIN 475-1.
  - Dimensional and geometrical tolerances according to ISO 2768-mK.
  - Surface texture according to ISO 1302.
  - Hose length not to scale.
  - $\triangle$  Critical dimension.
  - Packaging specific for client - No mention of Tucai in packaging.
  - Attach washer on hose with an elastic rubber band.
  - Working Parameters:
    - Minimum operating temperature: -20°C
    - Maximum operating temperature: 90°C
    - Maximum operating pressure: 10 bar

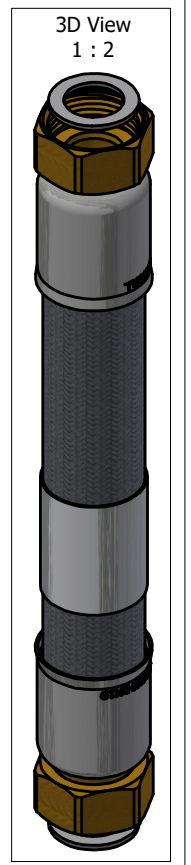
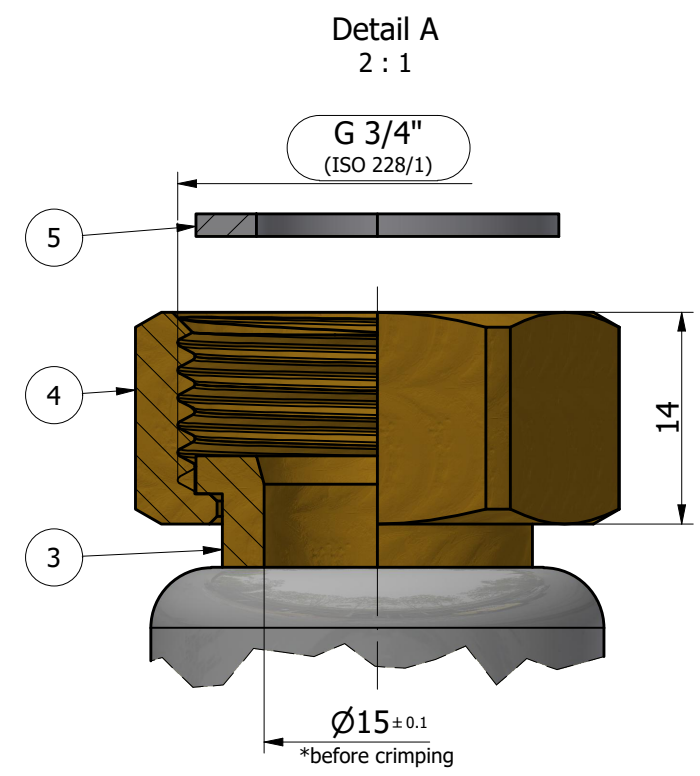
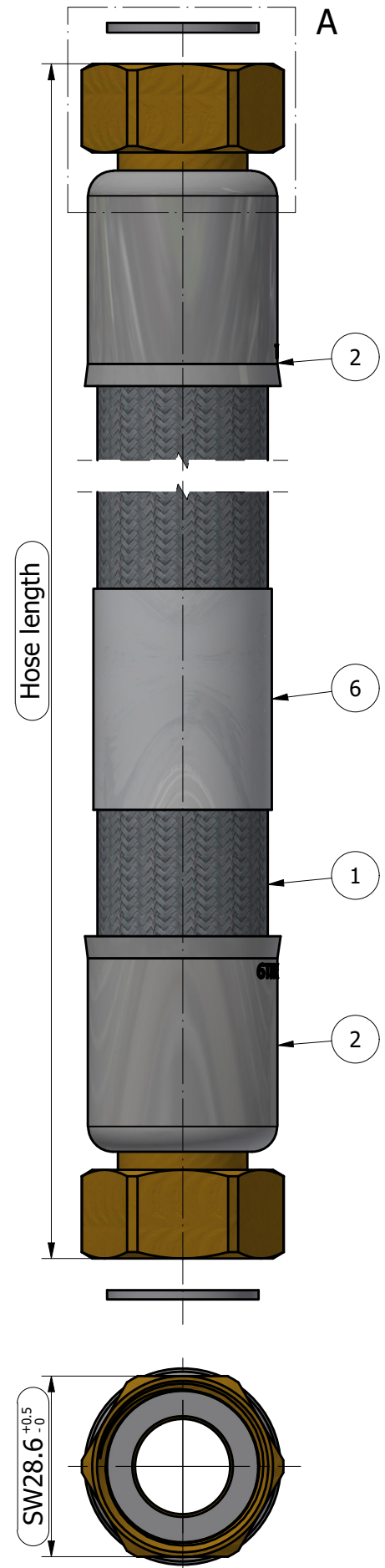

NON TOLERANCED DIMENSIONS	NON TOLERANCED ANGLES
from 0 to 6 mm. ± 0.1	Length (mm) of the shorter side of the angle concerned
from 6 to 30 mm. ± 0.2	from 10 to 50 mm ± 30'
from 30 to 120 mm. ± 0.3	from 50 to 120 mm ± 20'
from 120 to 400 mm. ± 0.5	from 120 to 360 mm ± 10'
BRASS MATERIAL SHALL BE STRESS RELIEVED	INSPECTION DIMENSION
NO SHARP EDGES PERMITTED	
NON DIMENSIONED RADII/US 0,5 mm.	
NON TOLERANCED HEXAGONS h13	
GENERAL SURFACE ROUGHNESS Ra 3.2	

a	29/11/2024	Initial release	9861	QAL	DDO
REV	DATE	DESCRIPTION	PET	DESIGNER	CHECKED BY
DESIGNER	QAL	29/11/2024	<h1>HOSE ASSEMBLY</h1>		
APPROVED BY	DDO	29/11/2024			
<b>tucai</b> www.tucai.com			EXTRA-TWIST-ACB-DN19-HG-3434-ARMATEC		Code <b>212173-T</b>