

MS 2150

SENSUSbase[®]



residia

Radio module for Residia Apartment Water Meters.

The radio module is compatible with the Sensus Apartment Water Meters in the Residia range. It records the meter reading by backlash-free pick-up on the litre wheel of the register and transmits the data into the SensusBase radio network. If fitted later on site or if the meter is changed, the parameters for the radio module can be set through an optical interface. When ordering a Residia water meter with the BaseR radio module the parameters are set ex-works and thus no longer have to be set on site.

Area of application.

The BaseR radio module is a component part of the SensusBase system.

It is used in conjunction with the Apartment Water Meters in the Residia range, whose data are to be registered within the SensusBase system. These could be meters for hot or cold water, in the single jet meter or multi-jet cartridge meter version. Further references to data sheets for our apartment water meters in the Residia range can be found on Page 2 of these operating instructions.

Functions.

- Registering the meter reading of the Residia Apartment Water Meters.
- Backlash-free inductive scanning of the litre wheel.
- Annual key date figure.
- Transmission of data by radio six times a day to the BaseNet / BaseGate network nodes of the SensusBase radio system.
- Optional sensing of dismantling and signal to the network nodes.

Delivery specification.

Radio module with operating instructions.
Adhesive security label.

Setting parameters on site

Setting the parameters on site is only necessary for later fitting or change of meter. If the Residia apartment water meter has been ordered directly with the BaseR radio module, setting the parameters is no longer necessary.

The following parameters can be set with the parameter software:

- Meter starting value.
- Meter number.
- Property number.
- Next key date.
- Delete errors.

Commissioning the radio

To sign the meter into the SensusBase radio system, an installation telegram must be triggered on the Residia radio module. This takes place with the radio commissioning code or with the parameter software through the optical interface. The pre-installed network nodes must be in installation mode at the same time. Further instructions on radio commissioning for the SensusBase radio system can be found in the operating instructions for the network nodes.

Project design hints

In order to ensure a perfect transmission of the data, the Residia radio module should be installed in positions where the propagation of radio waves is not prevented e.g. avoided installing in metal cabinets. In cases of doubt the propagation conditions should be tested with the PC Radio Module (BasePCradio).

www.sensus.com
info.int@sensus.com

MS 2150 Material-Nr. 28504368

 **SENSUS**
METERING SYSTEMS

MS 2150

Fitting instructions

1. When initially fitting on site the blanking cover of the Residia apartment water meter should be removed. The radio module can now be fitted into the free installation point.

Optical interface for setting the parameters on site and commissioning the radio.



2. Affix the adhesive security label provided.



3. If changing the meter, the module has to be removed from the old Residia register. After fitting the Residia Apartment Water Meter into the piping, continue as described for the initial fitting (1. and 2.).

Disposal instructions

This product contains a lithium battery and to protect the environment should not be disposed in household rubbish when its serviceable life is over.

Disposal can take place through a Sensus Metering Systems Service Centre. If however you want to take care of the disposal yourself, please comply with the local and national regulations for environmental protection.

Technical Data

CE - Conformity	89/336/EC (EMC Directive) 1999/5/EC (R&TTE Directive)
Enclosure Type	IP 65 mounted on meter IP 54 not mounted on meter In each case to EN 60529
Protection Class	III to EN 60950
Electromagnetic compatibility Immunity to interference	EN 301 489 -1 / -3 V1.2.1 (2000-08) EN 61000-6-2 :1999
Emitted interference	EN 300 220 -1 V1.3.1 (2000-09) -3 V1.1.1 (2000-09)
Safety of IT devices	EN 60950
Working voltage	DC 3 V Lithium
Service life	12 +1 years
Rated frequency	868,3 MHz
Transmission power	< 5 mW
Transmission frequency	6 times/24 h
Permissible ambient temperature during transport and storage in operation	-25...+60 °C 0... 55 °C
Weight	30 g

Dimensional diagram

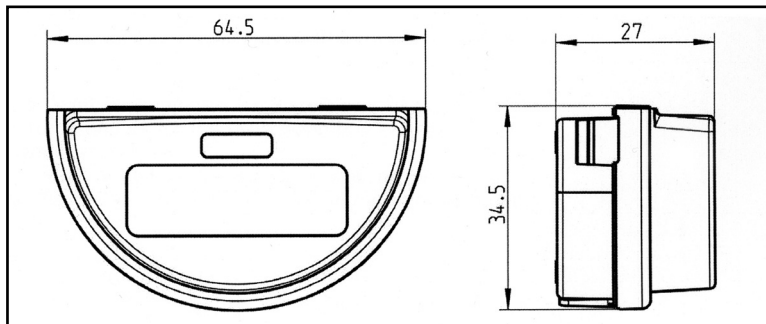

SensusBase Documentation summary

Unit	Type	Documents
SensusBase-System		Data Sheet LS 2100 INT
Heating cost distributor	BaseHxx	Data Sheet LS 2200 INT
Heat meters	PolluComE/C	Data Sheet LH 1100 INT and LH 1300 INT
	PolluTherm	Data Sheet LH 6100 INT
	PolluStatE	Data Sheet LH 4100 INT
Water meters	Residia...	Data Sheet LA 2100INT, LA 2110INT and LA 2200INT
	Sentinel...	see also. Data sheets for Sensus Domestic Water Meter
	Mei.....	see also. Data sheets for Sensus Bulk Water Meter

www.sensus.com

info.int@sensus.com

MS 2150 Material-Nr. 28504368

SENSUS
METERING SYSTEMS